

# Кровати

**Эльза**

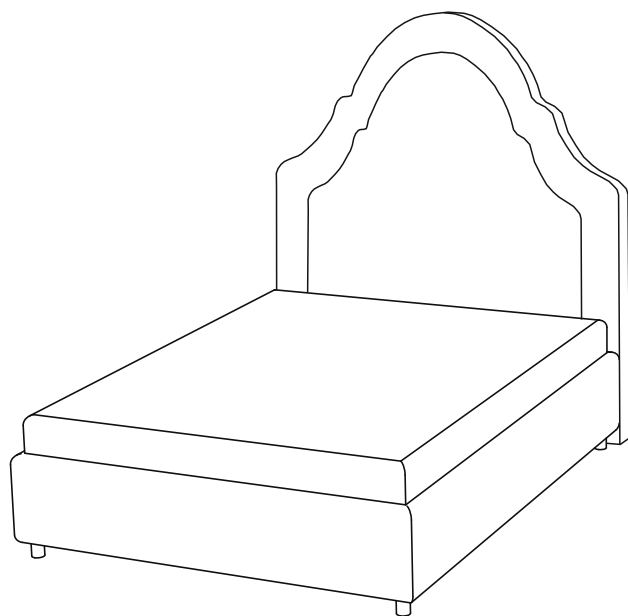

**Олаф**

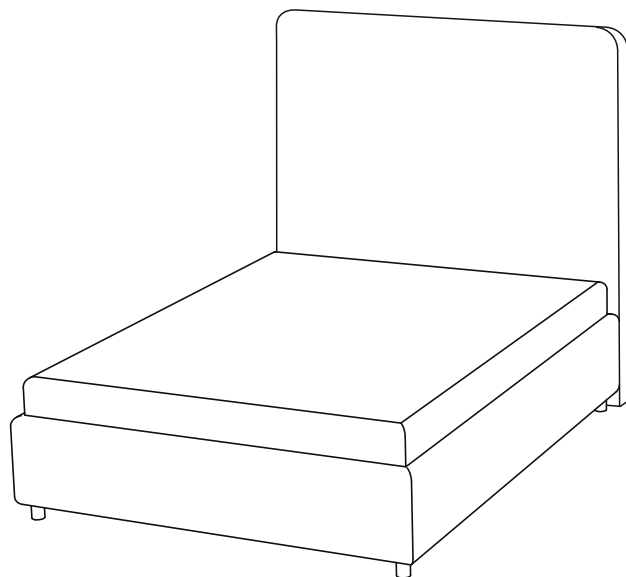

**PROXSON**

правила хорошего сна

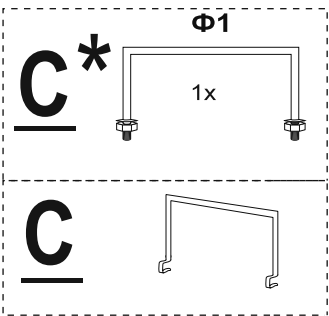
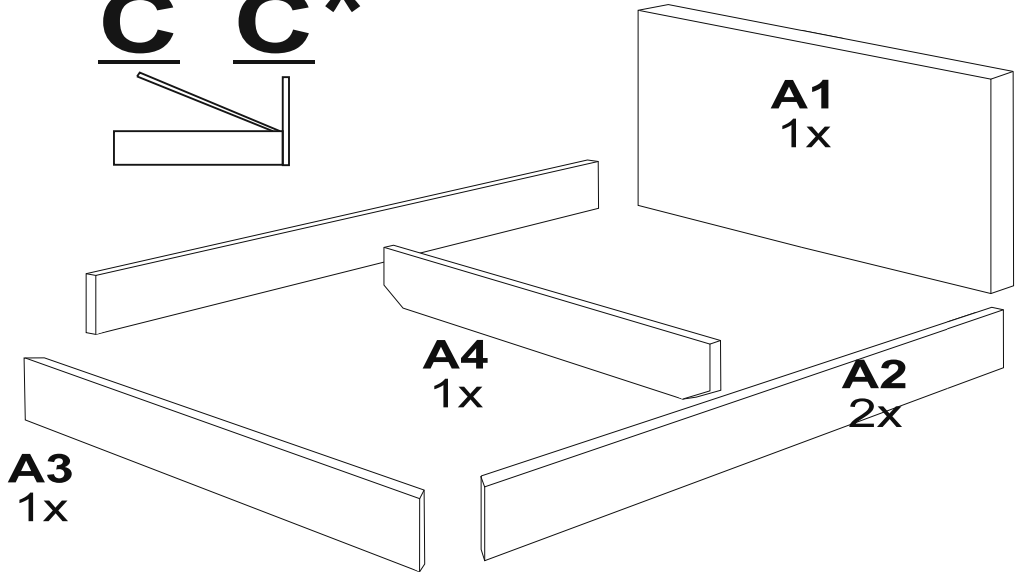
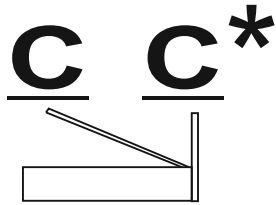
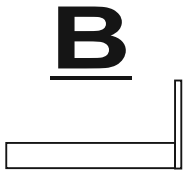

**Φ2**

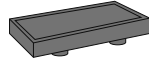

4x

**Φ3**

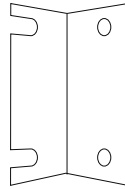

11x

**Φ4**

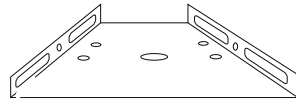

2x

**Φ5**



B 4x  
C 8x

**Φ6**

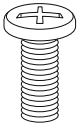

10x

**Φ7**

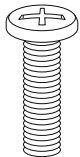

B 46x  
C 50x

**Φ8**

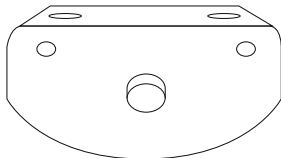

4x

**Φ9**

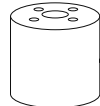

4x

**Φ10**

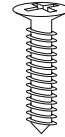

8x

**Φ11**



6x

**Φ12**



2x

**Φ14**

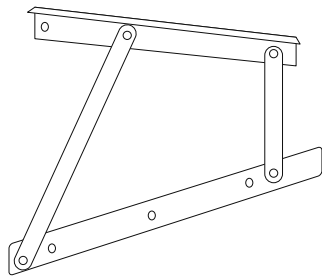

(Л+П) 1x

**Φ15**

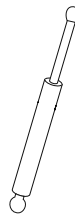

2x

**Φ16**

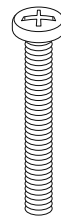

4x

**Φ17**

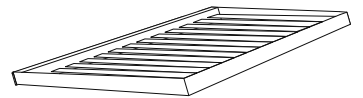

1x

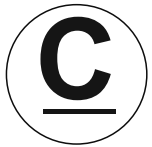

**Φ13**

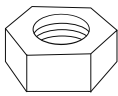

M8

4x

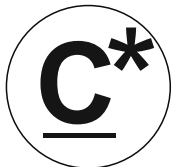

**Φ13**

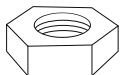

M8

4x

**Φ14**

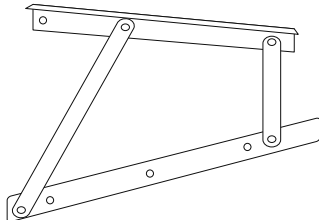

(Л+П) 1x

**Φ15**

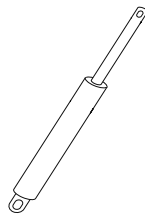

2x

**Φ16**

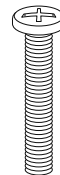

4x

**Φ17**



8x

**Φ18**



M6

4x

**Φ19**



4x

**Φ20**

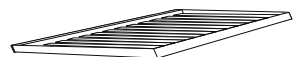

1x

**1**

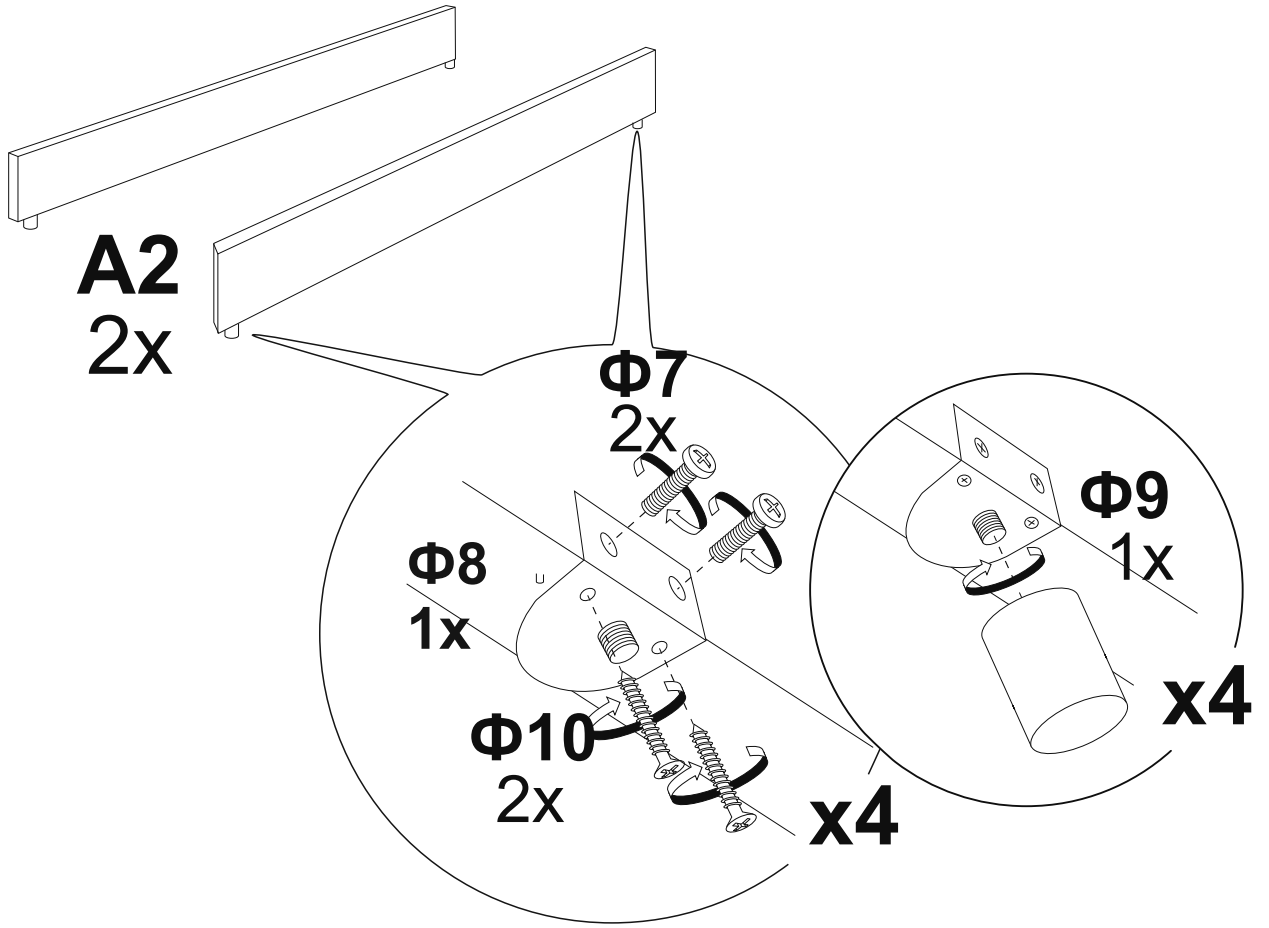

**2**

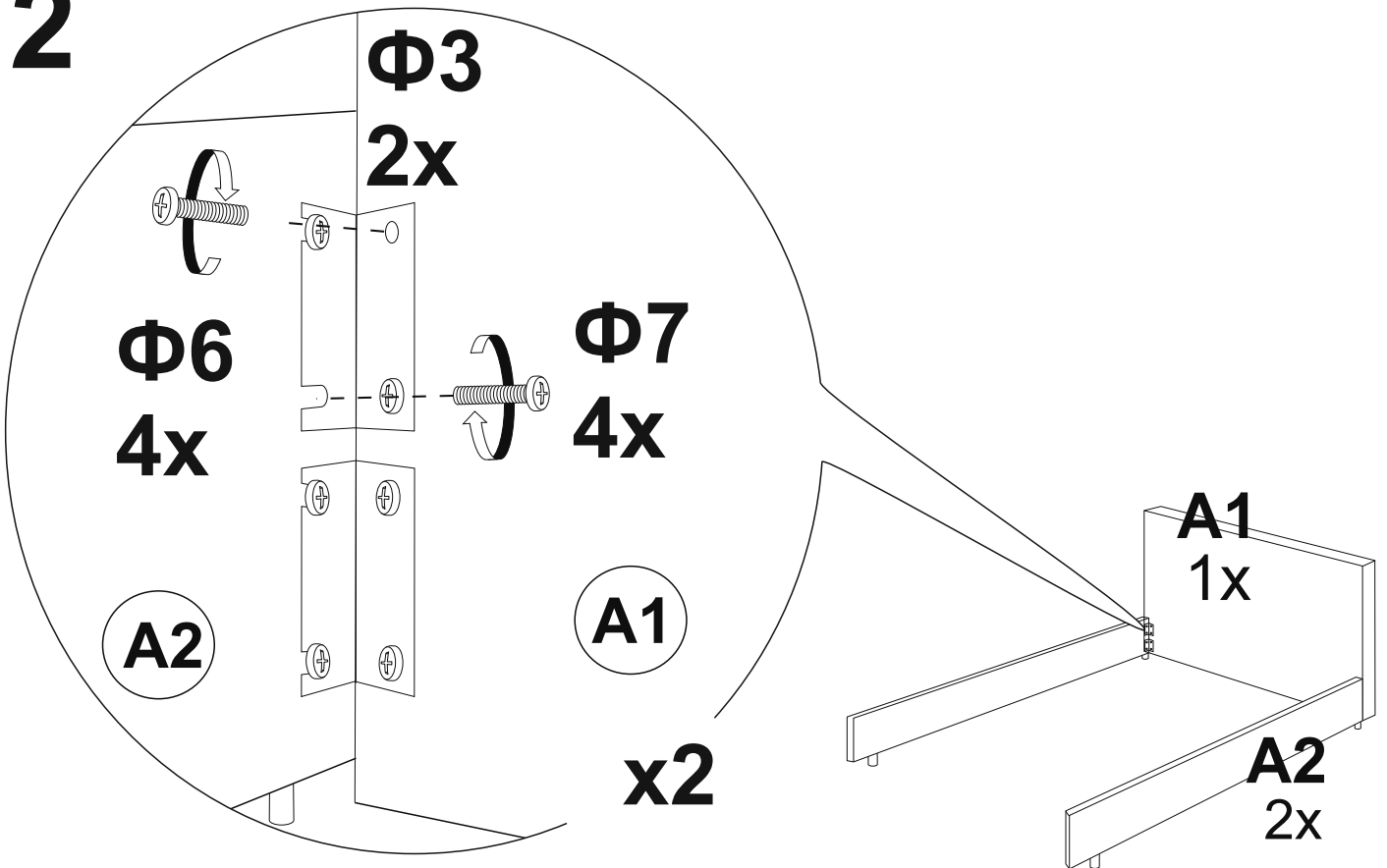

# 3

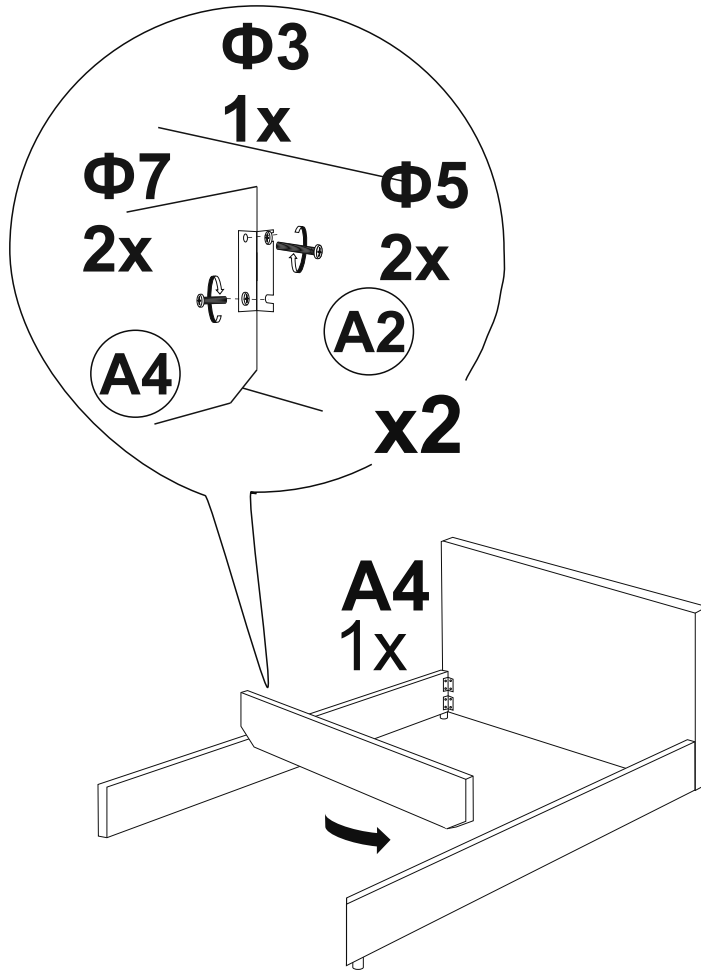

# 4

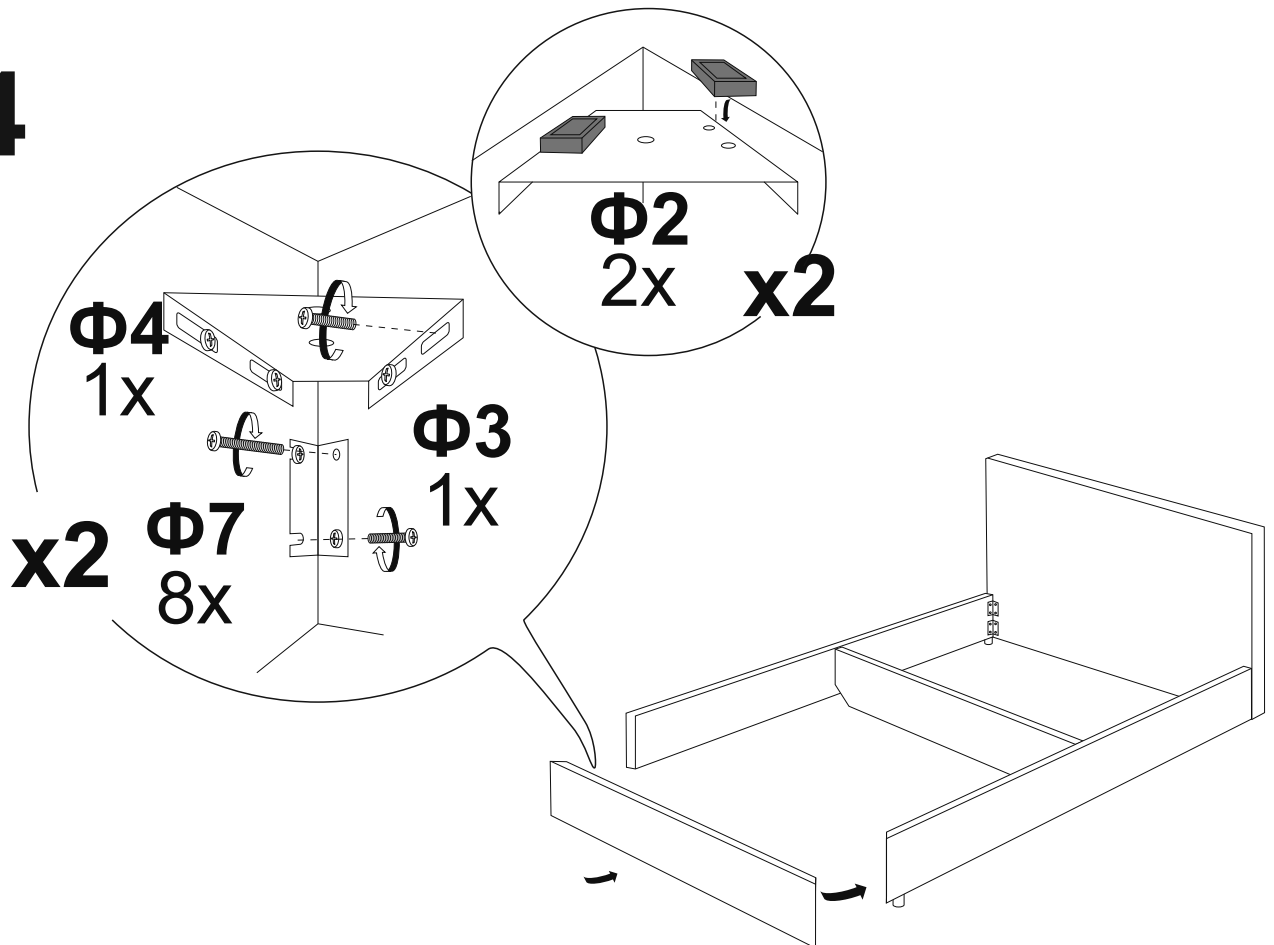

# 5 B

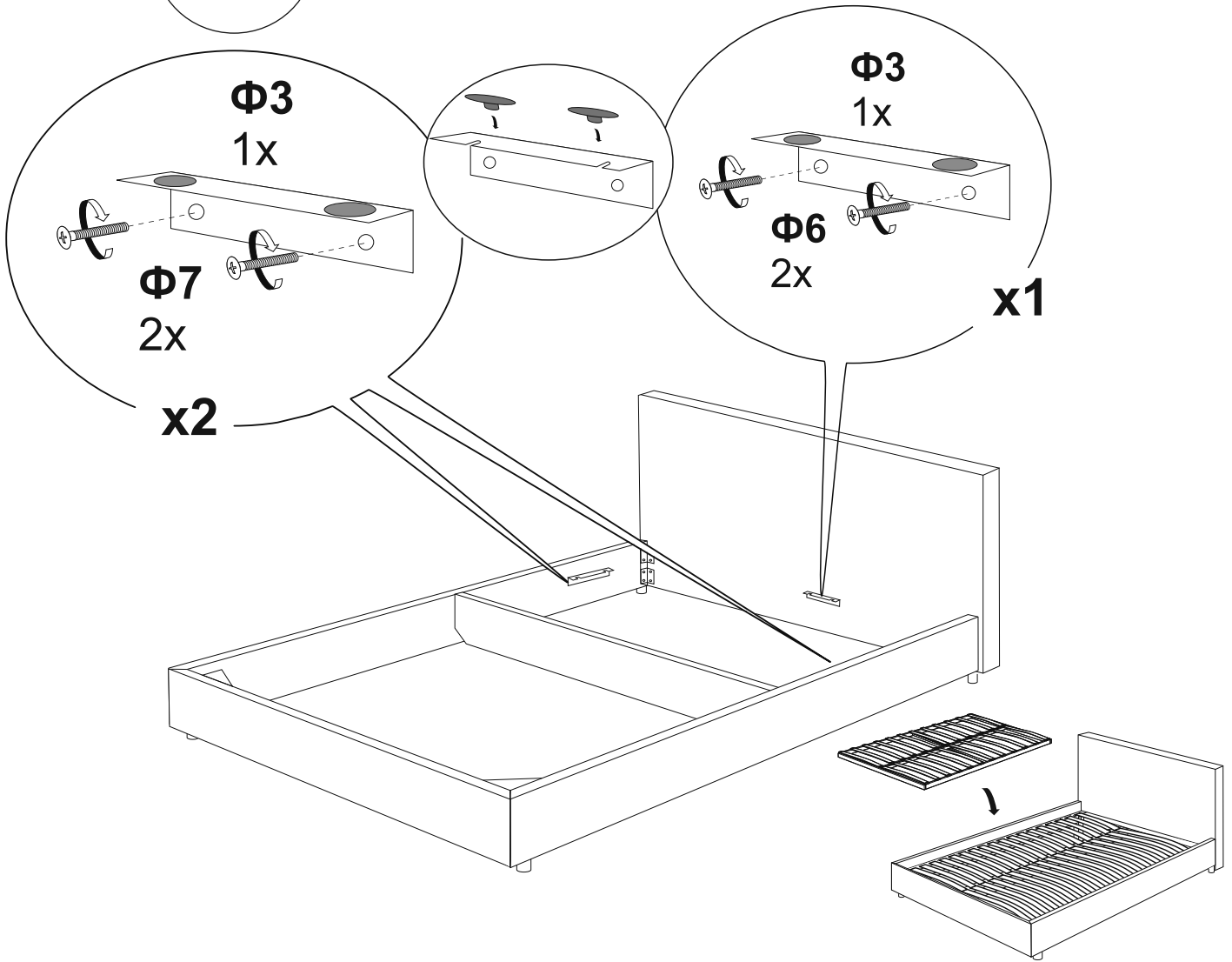

# 6 C

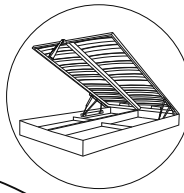

# C\*

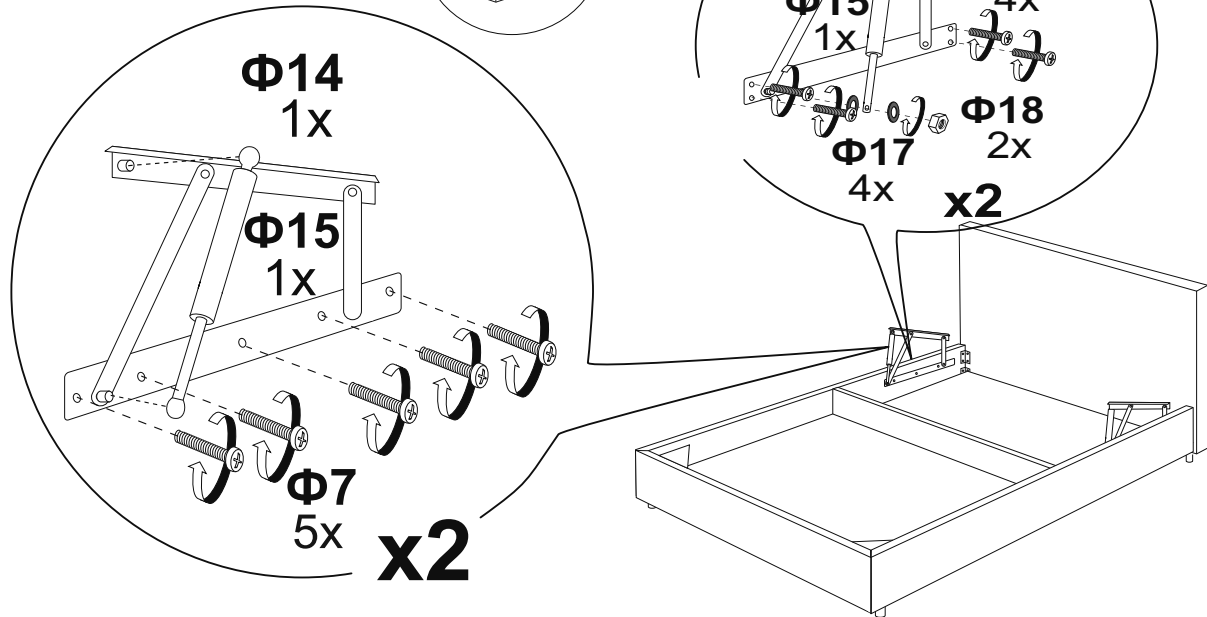

**7C**  
**C\***

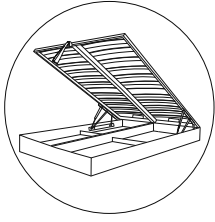

**Φ17** или **Φ20**  
**1x**

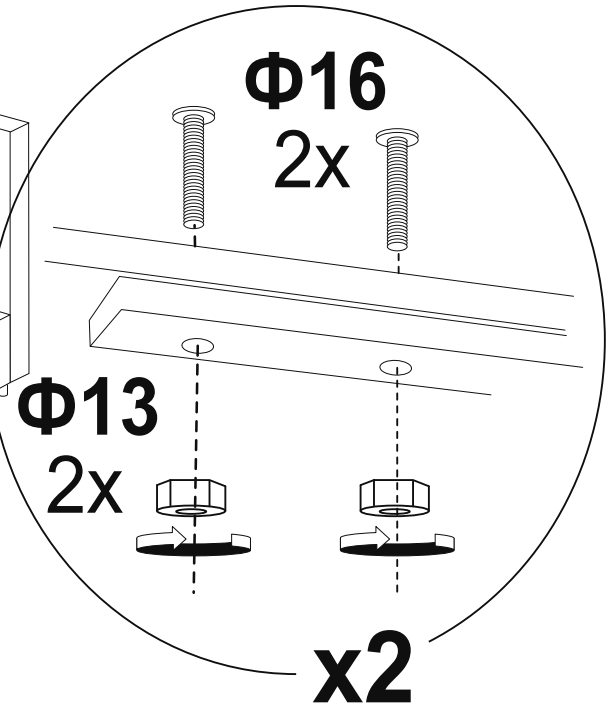
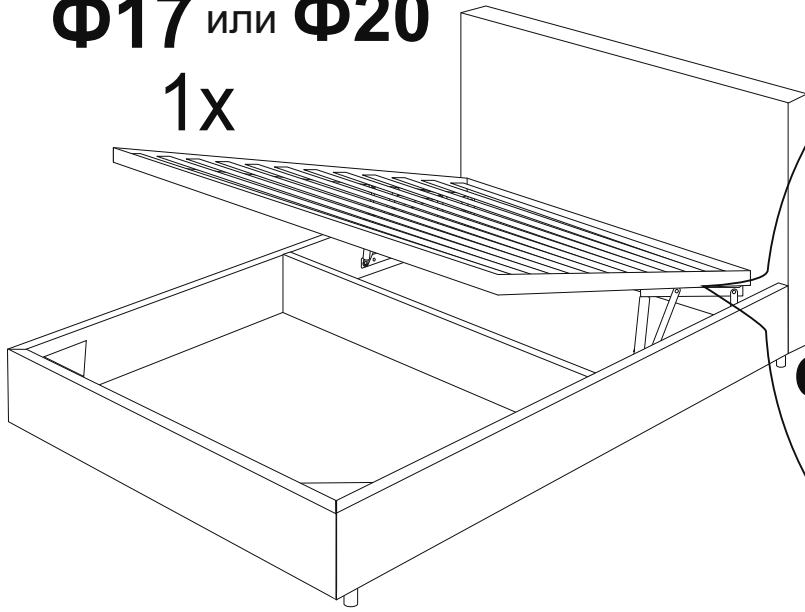

**8C**  
**C\***

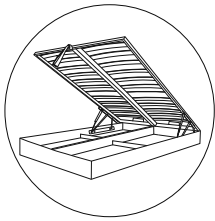

**Φ12**  
**1x**

